

ECE 214 - Lab #6

Inductors and the RLC Circuit

29 February 2024

Introduction

Additional features of the oscilloscope including input coupling and triggering are introduced. The inductor is introduced, and an RLC circuit is analyzed, simulated, and measured. The theoretical, simulated, and measured results are compared.

Parts List

1. 1 mH inductor (1)
2. 0.22 μF capacitor (1)

Pre-Lab

1. Watch the video series titled: "Tutorial - How to use an oscilloscope, Part 1, 2 and 3" located at <https://goo.gl/aYCn5g> You are already familiar with much of this information. However, make sure you understand the differences between AC and DC input coupling, and pay attention to the concept of triggering, especially the role of the trigger slope and the trigger level, and the difference between internal and external triggering. The input coupling and triggering features of the scope will be utilized in this and future labs.
2. Review the natural response and step response for a series RLC circuit from your notes in ECE 210. Make sure you can distinguish between under-damped, over-damped, and critically-damped circuits, and are able to determine the equations for the voltage across the circuit elements as a function of time.

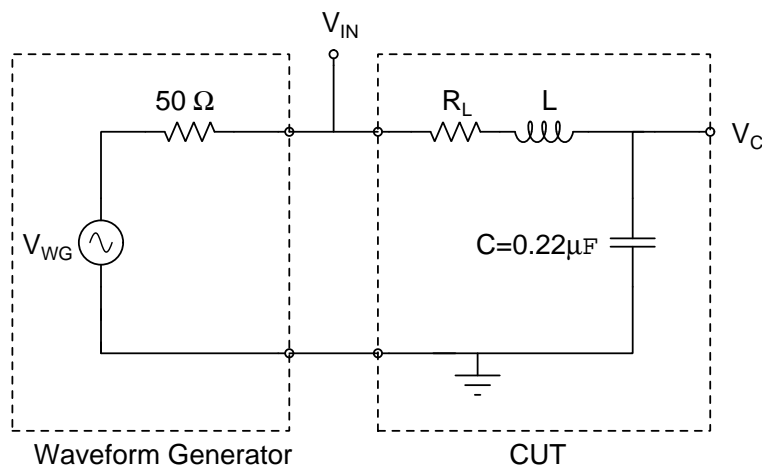

Figure 1: RLC circuit analyzed and measured in Lab #6.

3. Consider the circuit in **Figure 1** with $R_L = 0\ \Omega$ and $L = 1\ \text{mH}$.
- Calculate the phasor voltage across the capacitor ($\overline{V_C}$) and the phasor voltage across the inductor ($\overline{V_{IN}} - \overline{V_C}$) when the WG produces a 1 Volt peak sine wave at frequencies of 1 kHz, 10 kHz and 100 kHz.
 - Simulate the frequency response of this circuit (AC simulation) for frequencies between 1 kHz and 500 kHz.
 - Plot the magnitude of the node voltages $\overline{V_{IN}}$ and $\overline{V_C}$ as a function of frequency on one graph, and the voltage across the inductor $\overline{V_{IN}} - \overline{V_C}$ as a function of frequency on a separate graph. The frequency should be plotted on a logarithmic scale.
 - Plot the phase of the node voltages $\overline{V_{IN}}$ and $\overline{V_C}$ as a function of frequency on one graph, and the phase of the voltage across the inductor $\overline{V_{IN}} - \overline{V_C}$ as a function of frequency on a separate graph. The phase should be in degrees and the frequency should be plotted on a logarithmic scale.
 - Do the magnitude and phase of $\overline{V_C}$ and $\overline{V_{IN}} - \overline{V_C}$ from the simulation agree with your calculations at 1 kHz, 10 kHz, and 100 kHz? Include this data in a table in your lab notebook. The calculated and simulated results should agree to within $\sim 2\%$. Explain any differences.
 - If the WG produces a step function, does the circuit exhibit an under-damped, over-damped, or critically-damped response?
 - Derive the equation describing the voltage across the capacitor ($V_C(t)$) and the voltage across the inductor ($V_{IN}(t) - V_C(t)$) when the input is a 1 Volt step function. Calculate $V_C(t)$ and $V_{IN}(t) - V_C(t)$ at the time of $10\ \mu\text{s}$ and $40\ \mu\text{s}$.
 - Simulate the step response of this circuit (transient simulation) when the input signal is a 1 Volt step function. Simulate the transient response for $200\ \mu\text{s}$. Plot three voltages: $V_{WG}(t)$, $V_{IN}(t)$ and $V_C(t)$ on one graph, and plot the voltage across the inductor: $V_{IN}(t) - V_C(t)$ on a separate graph.
 - Compare the calculated results from **step 3e** to the simulated results from **step 3f** at $t = 10\ \mu\text{s}$ and $t = 40\ \mu\text{s}$. Include this data in a table in your lab notebook. The calculated and simulated results should agree to within $\sim 2\%$. Explain any differences.

Lab Procedure:

- Inductor measurement.
 - Obtain a nominal 1 mH inductor. Measure the inductance and quality factor Q using the LCR meter at frequencies between 30 Hz and 300 kHz. Record a sufficient number of values to be able to plot the inductance vs. frequency, and the Q vs. frequency, on a semi-log graph during the post-lab. Make sure to include frequencies of 20 kHz, 25 kHz, and 30 kHz, as they will be needed in Lab #7.
 - At each frequency measured, calculate the equivalent series resistance of the inductor from the measured values of Q.
 - Measure the DC resistance of the inductor using a DVM. Make sure the DVM reads $0\ \Omega$ when shorting the DVM leads together or subtract the offset from the measured results. Make sure you understand the difference between the equivalent series resistance and the measured DC resistance.

- (d) Determine the approximate number of turns of wire that are on the inductor. You can do this by turning the inductor into a transformer. When operating the transformer, make sure the input frequency is high enough such that the frequency is not influencing the measurements. Provide an explanation of how you determined the number of turns.
2. Build the RLC circuit shown in **Figure 1**.
 3. Set the waveform generator to produce a sinusoidal signal with a peak-to-peak voltage of 2 V. Verify on the oscilloscope that the function generator is producing the correct waveform. Measure the voltages at nodes V_C and V_{IN} on the scope.
 4. Measure the voltage across the capacitor V_C at frequencies of 1kHz, 10kHz, 50kHz, 100kHz, 300kHz, and 500kHz. Use the averaging function of the scope to reduce the random noise. If necessary, use the waveform generator as the trigger signal for the scope.
 5. Determine the frequency that produces a phase shift across the capacitor of 45° with respect to V_{IN} . Does the voltage across the capacitor lead or lag the input voltage at this frequency? Compare the measured results to the simulated results.
 6. Determine the frequency or frequencies that produce a phase shift across the capacitor of 90° with respect to V_{IN} ? Does the voltage across the capacitor lead or lag the input voltage at this frequency or frequencies?
 7. Adjust the function generator to produce a pulse from 0 to 1 V, with a pulse-width of 50 ms.
 8. Use the single trace button and the trigger controls on the scope to capture a single event. Capture the signals that appear at V_{IN} and V_C when a single pulse is captured. Click on the "Add Channel" button on the scope and use the Math function to generate the voltage waveform $V_{IN} - V_C$, which represents the voltage across the inductor. Record these three signals in your notebook, and measure the values of V_C and $V_{IN} - V_C$ at $t = 10\ \mu\text{s}$ and $t = 40\ \mu\text{s}$. The measured results should be similar to the simulated results from Pre-Lab section **3f**.

Post-Lab

1. Compare the measured results from the Lab Procedure **step 4** and **step 8** with both the calculated results from the Pre-Lab **step 3a** and **step 3e**, and the simulated results from the Pre-Lab **step 3b** and **step 3f**.
2. Using the data from Lab Procedure section **1a**, plot the inductance as a function of frequency, and the Q as a function of frequency, using a semi-log axis for the frequency.
 - (a) Explain the shape of the curve for Q as a function of frequency.
 - (b) Explain any differences in the resistance of the inductor calculated in **step 1b** and measured in **step 1c**.